

# Prime Conduit, Inc.

## Bore-Gard® Trenchless Raceway

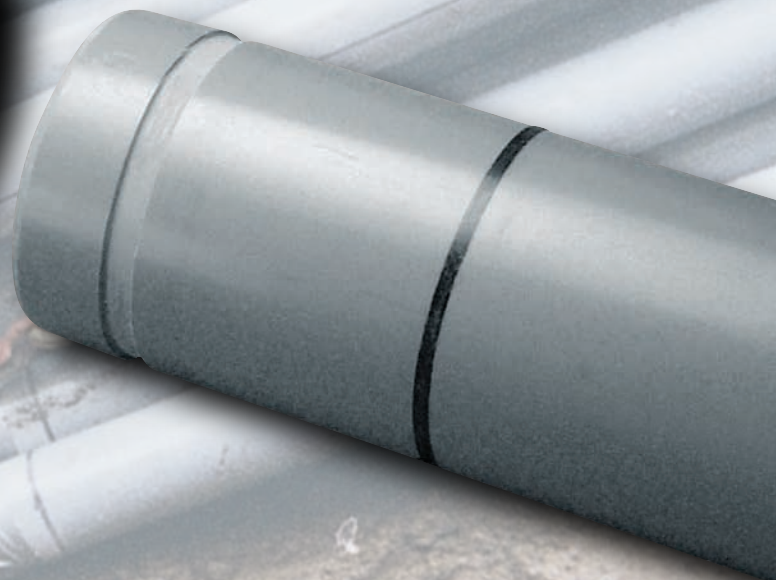



# Prime Conduit Bore-Gard®

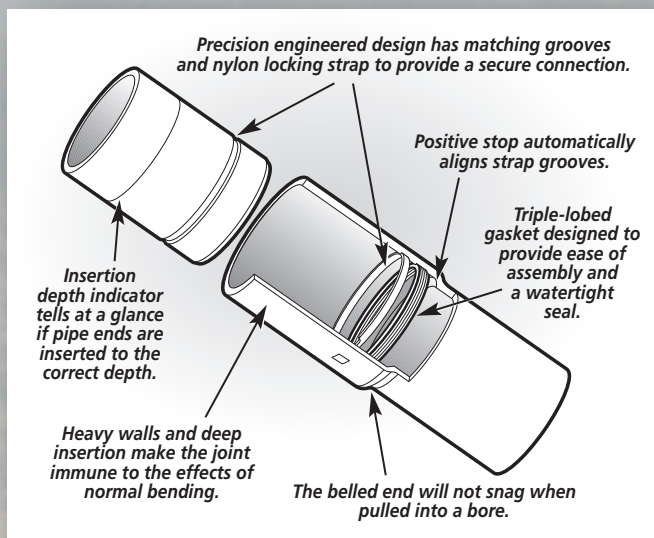

## ENGINEERED RACEWAY SYSTEM

The unique design incorporates a proprietary water-tight seal and locking ring that enables fast, cement-free assembly, strong enough for 1000 foot bores.



## LABOR - TIME - MONEY SAVER

Bore-Gard is a PVC trenchless raceway system utilizing horizontal directional drilling for electrical and datacom applications. Bore-Gard eliminates the costly problems of HDPE pipe on a reel, minimizes environmental disruptions in tight and confined spaces, and is easy to install.



## ELECTRICAL, UTILITY AND TELECOMMUNICATION MARKETS

Bore-Gard is perfect for under roads, highways, airport runways, railways and waterways, metropolitan/urban areas, or any other buried conduit application.



# The Preferred Trenchless Solution

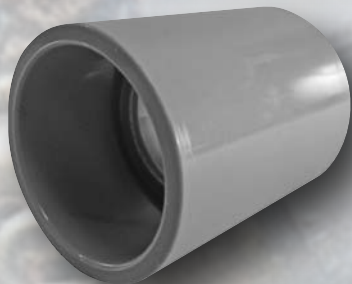

## ADVANTAGES OVER HDPE

HDPE ovalizes which reduces the internal capacity of the ducts. Bore-Gard is packaged in bundles, not wound on reels, so it does not collapse into an oval shape.

The Bore-Gard bundles are also easier to transport and results in less material waste. Because Bore-Gard does not use reels like HDPE, reel handling equipment is not needed, there aren't any costly reels to return, and there isn't the safety risk of uncoiling reels.

## USES STANDARD SCHEDULE 40 FITTINGS

Purchasing special Bore-Gard fittings is NOT required. In fact, they don't even exist! Bore-Gard uses standard, off the shelf, Schedule 40 fittings, making transitions faster, easier, and less expensive.

## FAST, EASY WATER-TIGHT CONNECTIONS

Prime Conduit's locking strap provides a fast, easy and secure connection. No cement or tools required. It also eliminates costly fusion welding. The locking strap is shipped installed with product. The factory installed gasket keeps out ground water and drilling fluid and has been tested to 80 psi.

## AGENCY APPROVALS AND MARKET ACCEPTANCE

Bore-Gard has been tested to UL651 standard and received ETL approval. It can be used for use with electrical conductors per The National Electrical Code articles 300 and 352. Bore-Gard is also proudly Made in the USA.



Intertek



NEMA



# The Easiest Installation

## PRODUCT INSTALLATION

1. Position Bore-Gard with the print line facing up.
2. Remove plastic locking strap and set it aside.
3. Remove end caps. On first stick only, trim spigot end of Bore-Gard at the groove before attaching the pulling eye/gripping attachment.
4. Insert pulling eye into spigot end of Bore-Gard.
5. Tighten pulling eye so that it expands against the interior of the conduit. Use of sleeve over O.D. of conduit is recommended.
6. The installer should use appropriate instrumentation to ensure that maximum pull rating is not exceeded. \*Note: lbf (pounds-force) is NOT equivalent to psi (lbf/in<sup>2</sup>). It is the responsibility of the customer to make that conversion (if needed) based on installation/equipment conditions.
7. Take next piece of Bore-Gard and insert spigot end into belled end of the first piece until the insertion line is no longer visible.
8. Slide the plastic locking strap into slot on the side of the bell. Push the strap in completely. It is not necessary to remove or cover the handle on the strap.
9. Repeat with remaining sections as space allows.
10. Bore-Gard is now ready for installation.



## PERFORMANCE SPECIFICATIONS

Bore-Gard is tested to a rigorous Pull test at 80 psi and a Bend & Pull test at a 65' radius and 80 psi.

# Prime Conduit, Inc.

## Bore-Gard® Trenchless Raceway Specifications



### PACKAGING

Part Number		Wall Type	Trade Size	Package Quantity (ft./bundle)		Bundles per Truckload		Feet per Truckload	Approx. Wt. per 100 ft. (lbs)
10'	20'			10'	20'	10'	20'		
BG340SP-010	BG340SP-020	Sch 40	3"	350	700	56	28	19,600	164
BG440SP-010	BG440SP-020	Sch 40	4"	260	520	56	28	14,560	234
BG540SP-010	BG540SP-020	Sch 40	5"	230	460	40	20	9,200	317
BG640SP-010	BG640SP-020	Sch 40	6"	200	400	40	20	8,000	418
BG840SP-010	BG840SP-020	Sch 40	8"	140	280	32	16	4,480	647
-	BG280SP-020	Sch 80	2"	-	2800	-	15	42,000	101
BG380SP-010	BG380SP-020	Sch 80	3"	350	700	56	28	19,600	210
BG480SP-010	BG480SP-020	Sch 80	4"	260	520	56	28	14,560	308

10 ft lay length = 9' 6"; 20 ft. lay length = 19' 6"

### TECHNICAL DATA

Part Number	Wall Type	Trade Size	<sup>1</sup> Avg. OD (in.)	<sup>1</sup> Min. Wall Thickness (in.)	<sup>2</sup> Pull Test (lbf)	<sup>3</sup> Bend & Pull (lbf)	<sup>4</sup> Min. Crush (lbs)	Listings
BG340SP	Sch 40	3"	3.500	0.216	7,500	7,000	1,000	ETL, CSA
BG440SP	Sch 40	4"	4.500	0.237	9,200	8,700	900	ETL, CSA
BG540SP	Sch 40	5"	5.563	0.258	11,800	11,300	900	ETL, CSA
BG640SP	Sch 40	6"	6.625	0.280	14,500	14,000	850	ETL, CSA
BG840SP	Sch 40	8"	8.625	0.322	18,500	*18,000	850	N/A
BG280SP	Sch 80	2"	2.375	0.218	3,150	3,000	2,000	ETL
BG380SP	Sch 80	3"	3.500	0.300	9,800	9,300	2,000	ETL
BG480SP	Sch 80	4"	4.500	0.337	12,500	12,000	2,000	ETL

<sup>1</sup> Average OD & Minimum Wall Thickness per UL651 & NEMA TC-2.

<sup>2</sup> Pull Test UL651 6.12.2.1 - @ 80 psi

<sup>3</sup> Bend & Pull UL651 6.12.2.2 - 65' Bend Radius @ 80 psi



\* 8" Bend & Pull tested at 60 psi/72' Bend Radius

The Bend & Pull and Pull test results are recorded in lbf (pounds-force). This is NOT equivalent to psi (lbf/in<sup>2</sup>). It is the responsibility of the customer to make that conversion (if needed) based on installation/equipment conditions.

<sup>4</sup> Schedule 40 - Meets UL651 6.9, NEMA TC-2, & CSA C22.2 No.211.2 6.3 ; Schedule 80 - Meets UL651 6.9

US Patent 6,789,629

### ACCESSORIES

Size	Locking Strap		Gaskets		Pulling Eyes	
2"	GSUP2		HBOR2		BG2PE	
3"	GSUP3		HBOR3		BG3PE	
4"	GSUP		HBOR		BG4PE	
5"	GSUP5		HBOR5		BG5PE	
6"	GSUP6		HBOR6		BG6PE	
8"	GSUP8		HBOR8		BG8PE	



# Prime Conduit, Inc.

## Product Summary

Visit [www.primeconduit.com](http://www.primeconduit.com) for more information



Product	Specifications						
Schedule 40 PVC Heavy Wall	<ul style="list-style-type: none"> <li>ETL Certified to UL651, NEMA TC-2, Federal Specification WC1094A</li> <li>1/2", 3/4", 1", 1 1/4", 1 1/2", 2", 2 1/2", 3", 3 1/2", 4", 5", 6"</li> <li>Concrete encased &amp; direct burial underground applications; exposed or concealed applications aboveground</li> <li>Rated for use with 90° C conductors</li> </ul>						
Schedule 80 PVC Extra Heavy Wall	<ul style="list-style-type: none"> <li>ETL Certified to UL651, NEMA TC-2, Federal Specification WC1094A</li> <li>1/2", 3/4", 1", 1 1/4", 1 1/2", 2", 2 1/2", 3", 4", 5", 6"</li> <li>Listed for aboveground &amp; belowground applications including areas subject to physical damage [352.12 (C)]</li> <li>Rated for use with 90° C conductors</li> </ul>						
Schedule 40 Heavy Wall PVC Utility	<ul style="list-style-type: none"> <li>Non-UL Listed, Designed for power utility applications</li> <li>1 1/2", 2", 2 1/2", 3", 4", 5", 6", 8"</li> <li>Concrete encased, direct burial, power utility applications; Rated for use with 90° C conductors or cable</li> </ul>						
Telephone Duct	<ul style="list-style-type: none"> <li>NEMA TC-10 &amp; Bellcore CA08546 (Types B and C)</li> <li>4" PVC: Type B &amp; Type B Heavy Wall, Type C, Type C Tel-Gard, Type D</li> <li>Concrete encased (Types B &amp; C), Direct Bury (Type C), Exposed Applications (Type D)</li> </ul>						
P&C Duct	<b>Type</b>	<b>Size</b>	<b>90° Cable</b>	<b>TC 6 &amp; 8</b>	<b>ASTM F-512</b>	<b>Concrete Encased</b>	<b>Direct Burial</b>
	* EB-20	2", 3", 4", 5", 6"	✓	✓	✓	✓	
	EB-35 Heavy Wall	2", 3", 4", 5", 6"	✓	✓	✓	✓	
	DB-60	2", 3", 3 1/2", 4", 5", 6"	✓	✓	✓	✓	✓
	DB-120 Heavy Wall	1", 1 1/2", 2", 3", 4", 5", 6"	✓	✓	✓	✓	✓
	DB-100	4", 5", 6"	✓	✓	✓	✓	✓
	DB-100 DWP	3", 4", 5"	✓	✓	✓	✓	✓
* EB-20 is ETL Certified to UL651							
Multi-Gard	<b>Material</b>	<b>Application</b>	<b>Type</b>	<b>Size</b>	<b>Approvals</b>		
	PVC	Outdoor - Direct Bury, Concrete Encased	Type C, Type 40, Type 80	3-Way 1 1/2", 4-Way 1 1/4"	UL Listed, ETL Certified to UL651		
	Fiberglass	Outdoor (UV Resistant) - Bridge Crossings, Areas Subject to Physical Damage (Bullet-Proof)	Heavy or Bullet Resistant	3-Way 1 1/2", 4-Way 1 1/4"			
	Steel	Outdoor - Bridge Crossings, Areas Subject to Physical Damage (Vandalism & Crush)	Galvanized or PVC Coated Steel	3-Way 1 1/2", 4-Way 1 1/4"	Conforms to NEC Article 300.22 and NFPA 90A for installation of communication cables inside buildings		
	EMT	Indoor - Inside Buildings	EMT	3-Way 1 1/2", 4-Way 1 1/4"	UL Listed EMT Outer Shell, Conforms to NFPA 90A for installation of communication cables inside buildings		
Boreable	Outdoor - Horizontal Directional Drilled	Type 40 PVC Outer Duct	3-Way 1 1/2", 4-Way 1 1/4"	Minimum Crush per CSA C22.2 No.211.2, UL 651 & NEMA TC-2			
Intra-Gard	<ul style="list-style-type: none"> <li>Schedule 40 &amp; Type C: 1 1/4", 1 1/2", 2"</li> <li>4-Way, 6-Way, and 4-Way Hybrid</li> <li>Direct bury &amp; concrete encased applications; Bellcore GR-356 Core</li> </ul>						
Bore-Gard Trenchless Raceway	<ul style="list-style-type: none"> <li>ETL Certified to UL651, CSA Certified (Schedule 40)</li> <li>2", 3", 4", 5", 6" &amp; 8"</li> <li>Horizontal directional drilling for electrical and datacom applications</li> </ul>						
PV Mold	<ul style="list-style-type: none"> <li>Exceeds NESC requirements, Designed in accordance with NEMA TC-19</li> <li>Standard Duty: 1", 2", 3", 4", 5"</li> <li>Heavy Duty Schedule 40: 1 1/2", 2", 3", 4", 5", 6"</li> <li>Extra Heavy Duty Schedule 80: 2" - 3"</li> <li>Pole riser system designed to protect communications power cable installed on poles</li> </ul>						
Split Duct & Kits	<ul style="list-style-type: none"> <li>Schedule 40 Duct &amp; Kits: 2", 2 1/2", 3", 3 1/2", 4", 5", 6"; Schedule 80 Duct: 2", 4"; C Duct &amp; Kits: 4" Repair broken ductwork</li> </ul>						
Fittings & Accessories	<ul style="list-style-type: none"> <li>Couplings, adapters, junction boxes, end bells, reducers, clamps, switch boxes, access fittings</li> </ul>						
Elbows & Sweeps	<ul style="list-style-type: none"> <li>Schedule 40, Schedule 80, DB Sweeps, and Telephone Duct Sweeps</li> </ul>						